

OPERATORS MANUAL & PARTS



Parts: Phone 00 64 7 8478492
Fax 00 64 7 8478406

Operators Manual (400 mat double acting clutch ram)

Introduction

The SAM Bulk Topdressers have been developed through 35 years experience in manufacturing fertiliser spreading equipment. We manufacture a reliable, ruggedly constructed versatile machine with models to suit a range of farming requirements.

Operation : Back Door Setting / Spreading centres

The sliding door at the back of the bin must first be set to the required sowing rate. With the floor chain speed controlled by the speed of the wheels, the rate is always constant at a given back door setting. The door settings on the chart are a guide only - all types of manure flow differently and we always recommend spreading the first load into a measured paddock to check the rates carefully. The spreader rate charts printed in this manual are more complete than the chart on the back of the topdresser showing a rate for a wider selection of fertilisers. The spread rates (door settings) are usually very similar for fertilisers of the same density and granule type. Density is measured in tonnes per cubic metre and can vary from N.Z. Urea @ .77 Tonnes per Cubic Metre to Lime @ 1.6 T per Cubic M . We have also included on the chart a selection of BOP Fertilisers with their densities.

Spreading centres are the second important factor to take into account when spreading fertiliser. We suggest on the chart on the back of the bin spreading at 15 metre centres for granulated fert and 10 metres for powdered or very fine granules like lime. We have also shown on our detailed chart spread widths of 17.5 & 20 metres. With rates over 500kg per HT it is sometimes a good option to select a closer spacing with a lower door setting.

Keep to spreading centres to distances suggested on the rate charts

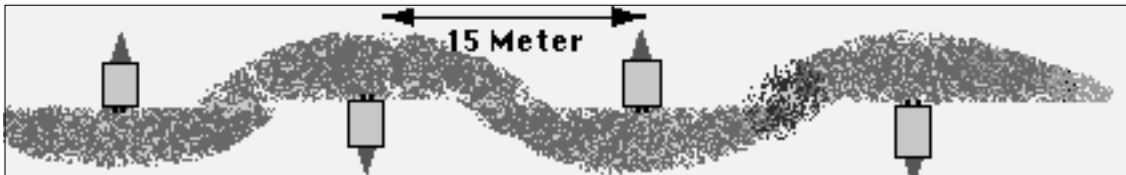

We suggest:

15 m to 20 m centres for the twin spinner with granulated product (super etc.)

10 m for fine or powdered products (Lime).

The 4.00 Tonne Twin Spinner bin holds approximately 3.2 cubic m of fert

= 4.00 Tonne super @ 1.3 t/m density, 5.50 Tonne lime @ 1.7 t/m density. 2.6 Tonne urea @ .8 t/m

The 5T Twin Spinner bin holds approximately 3.9 cubic m of fert

= 5.00 Tonne super @ 1.3 t/m density, 6.6 Tonne lime @ 1.7 t /m density. 3.1 Tonne urea @ .8 t/m

The 6T Twin Spinner bin holds approximately 4.6 cubic m of fert

= 6.00 Tonne super @ 1.3 t/m density, 7.7 Tonne lime @ 1.7 t /m density. 3.7 Tonne urea @ .8 t/m

(Australian Models)

3.0 Tonne Bin holds 2.53 cubic metres

= 3 t super = 4.0 t lime = 2.0 t urea

Hydraulics

The standard SAM Topdresser is fitted with two hydraulic motors (OMP32) **running in series**, requiring an external oil flow of 35 litres per minute at 2000 psi. If the hydraulic flow from the tractor is adjustable then wind the flow back to the recommended 35 litres per min. If the two motors are run in series with flows over 35 lit the extra oil flow is automatically bypassed back to the tractor through the built in flow control valve. The higher the bypass flow, the higher the pressure in the system. To keep the pressures as low as possible keep the flow down to the recommended 35 to 40 lit per min (If the tractor external hydraulics has a flow of between 24 litre and 34 litre, we can supply alternate motors OMP25).

For tractors with flows in excess of 55 litres per minute where the oil flow cannot be controlled to lower rates (35 lit per min) from the tractor, then the Two motors should be run in parallel.

Two motors to be run in parallel. This option would give the discs more torque and run the spinners at lower pressures but the topdresser would then only operate with a minimum of 55 lit. flow. To change to a parallel system requires a 3/16" and a 6mm Allen key and half an hour labour. (See separate instruction sheet if required) The pre-set spinner speed must also be reset as per instruction sheet.

Coupling the Hydraulics

The live hose (red end) must be coupled to a high pressure outlet point on the tractors external system. This take off point can be fitted to an existing double acting valve already fitted for loaders, feedwagons, rams etc or a new fitting can be installed.

The return hose (yellow end) must be coupled into the same double acting bank using the quick release coupling supplied.

To operate clutch follow the instructions on the shaded label on the front of the machine. The feed conveyor has an in out clutch (incorporating a ram) that is activated automatically from the tractor seat when the hydraulic spinners are started.

To start the spinners and engage the clutch. Pressurise red hose and the clutch is in gear and the spinners are turning.

To stop the spinners and put the clutch out of gear move the hydraulic lever to pressurise the yellow hose for one second then place the lever to neutral.

The hydraulic twin spinner must be coupled correctly to the tractor hydraulics system. Contact either your local agent or the manufacturer if there is any doubt. The adjustable flow control valve on the hydraulic motor valve block controls the spinner speed. This is pre-set in the factory .

(Danfoss OMP32 motor in series = wind all the way in then 1-5/8 turns out for 850 RPM)

(Danfoss OMP32 motors in parallel = wind all the way in then 2-1/4 turns out for 850 RPM)

If coupling hydraulics to a **John Deere tractor** (30,40,or 50 series) the oil in the live hose may need to be restricted with a needle valve, to a flow less than the charge pump capacity. On late model John Deere tractors with built in flow controls, leave the topdressers flow control valve (Black Knob) on the topdresser motor set as per above, and then adjust the tractors built in flow control down to 35 lit per min and leave set in this position. Mark position if necessary. If there is any pulsing in the hydraulics please phone for a simple remedy.

Check with Coombridge & Alexander Ltd if unsure.

Always ensure tractor oils are kept in top condition. Beware when changing machine from one tractor to another unless they use the same hydraulic oils (pump oil out of hoses into a tin). If the hydraulic system is coupled correctly when new it will return excellent results. Beware of the traps and always consult an expert if in doubt.

General Safe Use of a SAM topdresser involves following several safe work practices (also listed in this handbook in the machinery risk assessment page) including:

!!! TURN OFF TRACTOR BEFORE REMOVING GUARDS OR SERVICING !!!

!!! READ ALL WARNING LABELS ON THE MACHINE !!!

!!! NEVER USE YOUR HANDS TO CHECK FOR OIL LEAKS !!!

!!! STAY AT LEAST 15 METERS CLEAR OF THE TURNING SPINNERS !!!

!!! DON'T RIDE ON THE TOPDRESSER !!!

!!! DON'T USE THE MACHINE IN STEEP AREAS WHERE THERE IS A RISK TO THE OPERATOR OF A ROLLOVER OCCURRING !!!

General Maintenance

1. Check the hydraulic system before each use for signs of leaks or wear. To locate small leaks, use a small piece of cardboard paper or wood. **!!! NEVER USE YOUR HANDS !!!**
2. All roller chains should be kept well oiled especially when the machine is placed in storage for any period of time.
3. Tyre pressure for the 11.5 x 15 .3 tyres should be between 35-45 p.s.i.
4. After initial 10 hours use check all bolts are tight, including the wheel nuts.
5. **Grease every five hours** all nipples on the front and back floor shafts and the four high speed spinner bearings. Don't spare the grease gun.
6. **Grease every ten hours** all nipples and grease points on front floor adjuster slides, front screw jack, clutch pivot bearings, back door screw jack, all hubs, and nipples on the pivot points on tandem axles
7. Floor conveyor tension to be an even curve from front to rear with 40mm sag below the chassis.
8. Check (by lifting up on the spinner) that there is not too much play in the spinner bearings. Tension spinner bearings by undoing the grub screw in the large nylock nut and tightening this nut to take out any play in the bearings. Retighten the grub screw.

Good maintenance along the lines already mentioned will keep your machine in top working order for years to come. Always ensure the mesh grill inside the bin remains in place for all sowing rates below 1/2 ton to the acre. If the mesh grill is left out and rocks catch between the back door and the floor mat serious damage can occur. The Machines guarantee is invalid if mesh screen is not used.

To Change The Two Motors From Series to Run in Parallel

(with H Compensator from May 2003)

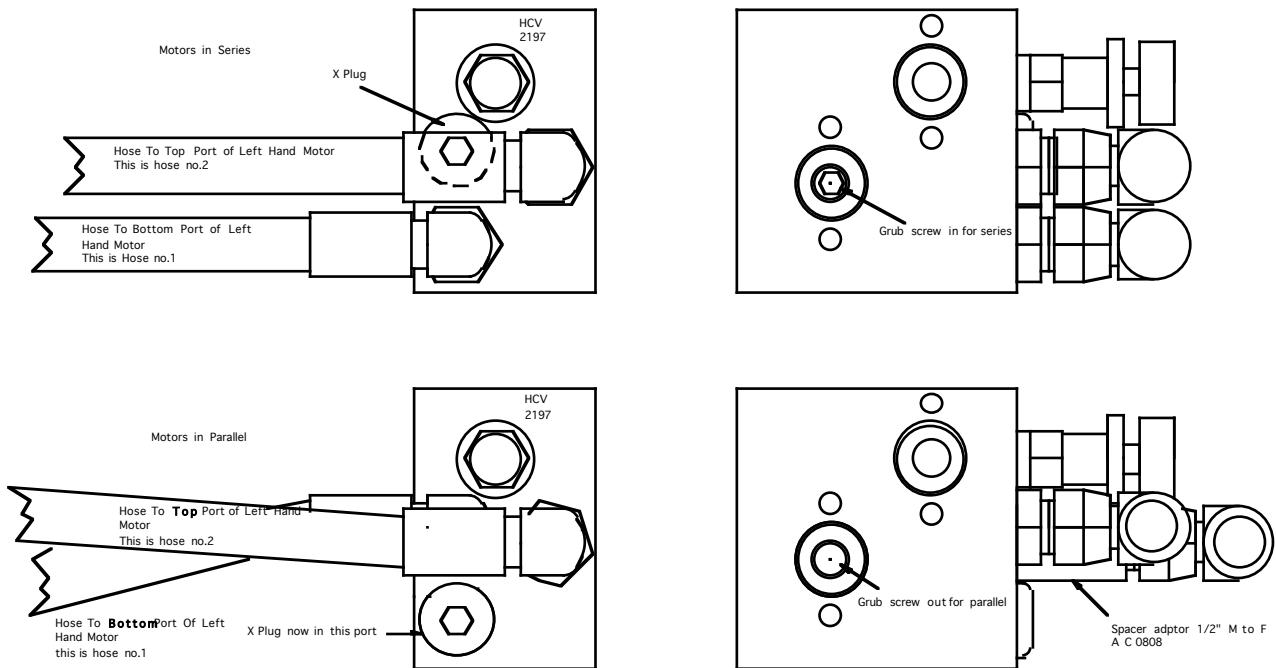

1. Remove the four allen head cap screws with a 6mm allen key. These screws hold the alloy block onto the RH motor.
2. Carefully remove the block away from the motor (watch the two O rings) and with an 1/4" allen key remove the grub screw from inside the lower of the two holes. (See dia above for grubscrew) Hint!! If this grubscrew is tight give it a hard tap with a punch or similar to free up.
3. Bolt the block back onto the motor (watch the two O rings are in place)
4. Remove the two hoses that run between the two motors at the block end only. Remove the plug from the parallel pressure port (marked on the drawing as X Plug) and put the plug back into the pressure series port below it. The allen key size is 3/16".
5. The hose marked hose no.1 now goes to the port marked parallel pressure (this is the port where you just removed the X plug.)
6. The hose marked no.2 goes back onto its original port (marked Motor Return). A spacer male to female adaptor may be required to space the hose out from the no.1 hose see drawing.

Test run to ensure there are no leaks. The motors are now set up to run in parallel. The spinner speed must be reset on the alloy block to give a speed of approx 850 RPM. This setting should be : wind all the way in then 2.25 turns out for parallel. (1-5/8 for series)

Questions Often asked:

Question : *What rates will the machine spread at ?*

Answer : From 45 Kg per Ht @ 15 m Centres for urea etc up to 3000 Kg per Ht @ 10 m centres for lime

Question : *How even is the spread ?*

Answer : Representative machines have been tested using the recognised spread mark test for spreader accuracy. Spread patterns are rated using the term Coefficient of Variation, a measure of the % of fertiliser outside a perfect spread with 0% being perfect. New Zealand Standards recognise a CV under 15% as Being acceptable for nitrogenous fertilisers (DAP urea nitroposka blue etc.), and under 25% for other products (super lime etc.) The SAM Spinners have been tested at 7.1% CV with urea and 8.1% CV with super well within the standards.

Question : *What is the capacity of the machine ?*

Answer : The 4.00 Tonne Twin Spinner bin holds approximately 3.2 cubic m of fert = 4.00 Tonne super , 5.50 Tonne lime . 2.6 Tonne urea

The 5T Twin Spinner bin holds approximately 3.9 cubic m of fert = 5.00 Tonne super, 6.6 Tonne lime 3.1 Tonne urea

The 6T Twin Spinner bin holds approximately 4.6 cubic m of fert = 6.00 Tonne super , 7.7 Tonne lime . 3.7 Tonne urea = 3 Tonne urea @ .8t/m density

(Australian Models) 3.0 Tonne Bin holds 2.53 cubic metres = 3 t super = 4.0 t lime = 2.0 t urea

Question : *How does the automatic clutch work ?*

Answer : As the hydraulic spinners are started (Red hose pressurised) oil also opens a hydraulic ram inside the clutch assembly which engages the two gears to start the floor mat. When the spinners are stopped (Yellow hose pressurised for two seconds) and the lever returned to neutral, the two gears are automatically disengaged stopping the floor mat. The system works perfectly engaging and disengaging on the move.

Question : *What is the expected life of the gears ?*

Answer : As they are only engaging at low pressure they will last for many thousands of tonnes

Question : *What oil flow is required ?*

Answer : The standard SAM Topdresser is fitted with a hydraulic motor (OMP32) requiring a minimum external oil flow of 35 litres per minute at 2000 psi. Any oil flow greater than 35 lit see instructions Hydraulics . If the tractor external hydraulics has a flow of between 24 litre and 34 litre we can supply an alternate motor (OMP25). If the flow is over 55 Lit see the section on running the motors in parallel.

Question : *What paint treatment does the machine receive ?*

Answer : Chassis - Blast to Sa 2.5 Paint Devshield 236 (2 pot) Paint E Line 929 (2 pot)
Bin - Blast to Sa 2.5 Paint cathacoat zinc 232 then as above.

Question : *How tight should I have the floor chain / mat assembly ?*

Answer : The chain should return 40mm below the chassis.

Question : *Are there different tyre options ?*

Answer : Yes the standard tyres are 11.5 * 80 * 15.3 * 12ply but other sizes both wider and larger in diameter are available

Question : *Are the spinners spinning in the correct direction ?*

Answer : Looking down on the disks from a position behind the machine, the right hand disc should be turning clockwise with the left disc turning anti-clockwise.

Question : *How can I stop lumps of urea blocking the back door ?*

Answer : Lay a sheet of chicken wire over the mesh grill. The type with 1/2" holes so that only the granules of urea will fall through and not the lumps.



HEALTH & SAFETY MACHINERY RISK ASSESSMENT

SAM Tractor Drawn Bulk Topdressers



A hazard identification, risk assessment and risk control procedure has been carried out on a representative example of a SAM topdresser and where found necessary the appropriate risk control measures have been incorporated in the product specifications. The operators manual contains the necessary information, and safety warnings are applied to the machine where necessary.

What is a hazard? A hazard is any situation that may cause injury or illness.

Risk Assessment Rating : Measures the probable frequency of an accident against the potential severity.

		Severity Potential			
		Fatality	Major injury	Minor injury	Negligible Injury
		4	3	2	1
Very Likely	4	16	12	8	4
Likely	3	12	9	6	3
Unlikely	2	8	6	4	2
Highly Unlikely	1	4	3	2	1
Probable Frequency					

Hazard:	Potential Risk Source:	Fre	Sev	Rating	Safety Measure:
Damage to limbs crushing, abrasions	Moving Chains, Moving Gears.	1	2	2	Warning labels / Instruction Book / Guards Gears and chains can only move with machine in motion
Entanglement, drawing in, trapping	Moving Vee Belts	1	2	2	Warning labels / Instruction Book / Guards
Damage to fingers / eyes through high pressure fluid ejection	Hydraulic Oil Pressure Leaks	2	2	4	Warning in Instruction Book / Adequate pressure ratings for all components
Instability under varying conditions	Machine Roll Over	2	4	8	Warning in Instruction Book / Adequate weight on hitch / Adequate wheel track
Slipping tripping or falling	Riding on Machine	2	2	4	Warning in Instruction Book
Damage to fingers / eyes through ejection of material	Rotating Spinner discs	1	1	1	Warning in Instruction Book / Pipe frame around discs / Rotation direction
All the above hazards	Lack of information				Operators manual with safety and operating information